

## 10 464 5KF 00 GROHE ARENA AQUA TILES FLUSH PLATE WITH SILK MOTION TECHNOLOGY

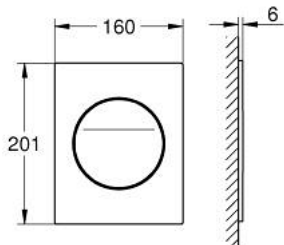

### PRODUCT DESCRIPTION

- Colour: phantom black
- for dual flush actuation
- for pneumatic discharge valve AV1
- vertical installation
- 160 x 201 mm
- material: ABS
- GROHE EcoJoy - less water, perfect flow
- for combination with Rapid SL and Uniset with GD 2 cistern, slim cistern and 80 mm cistern
- 6V lithium battery, type CR-P2
- battery lifetime: 4 years for a 3 person household (approx. 17000 actuations)
- battery status warning
- auto flush
- cleaning mode
- for mains supply please order transformer 100 686 9990



## 10 464 5KF 00 GROHE ARENA AQUA TILES FLUSH PLATE WITH SILK MOTION TECHNOLOGY

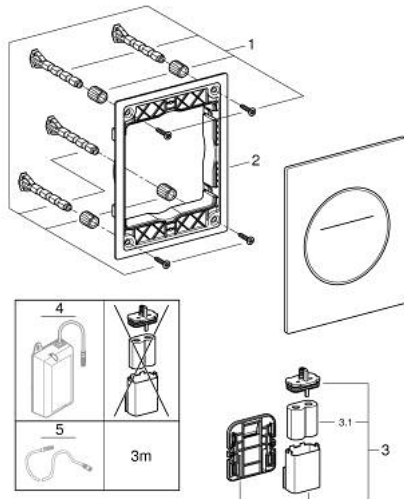

### SPARE PARTS

- 1: mounting set (Spare part-nr. 107288999M)
  - 2: retaining frame (Spare part-nr. 1072879990)
  - 3: Battery housing with battery (Spare part-nr. 42393000)
  - 3.1: Battery (Spare part-nr. 42886000)
  - 4: Transformer (Spare part-nr. 1006869990)\*
  - 5: Power extension cable (Spare part-nr. 36340000)\*
- \* Optional accessories